

TOOLING EXPERTS DRIVEN BY EXCELLENCE

Alu Line

Die schreurs Serie für Aluminium

NEU IM PROGRAMM

Eignet sich für vielfältige Anwendungen
in Aluminium, Kupfer und Kunststoffen

Hervorragende Oberflächenqualität

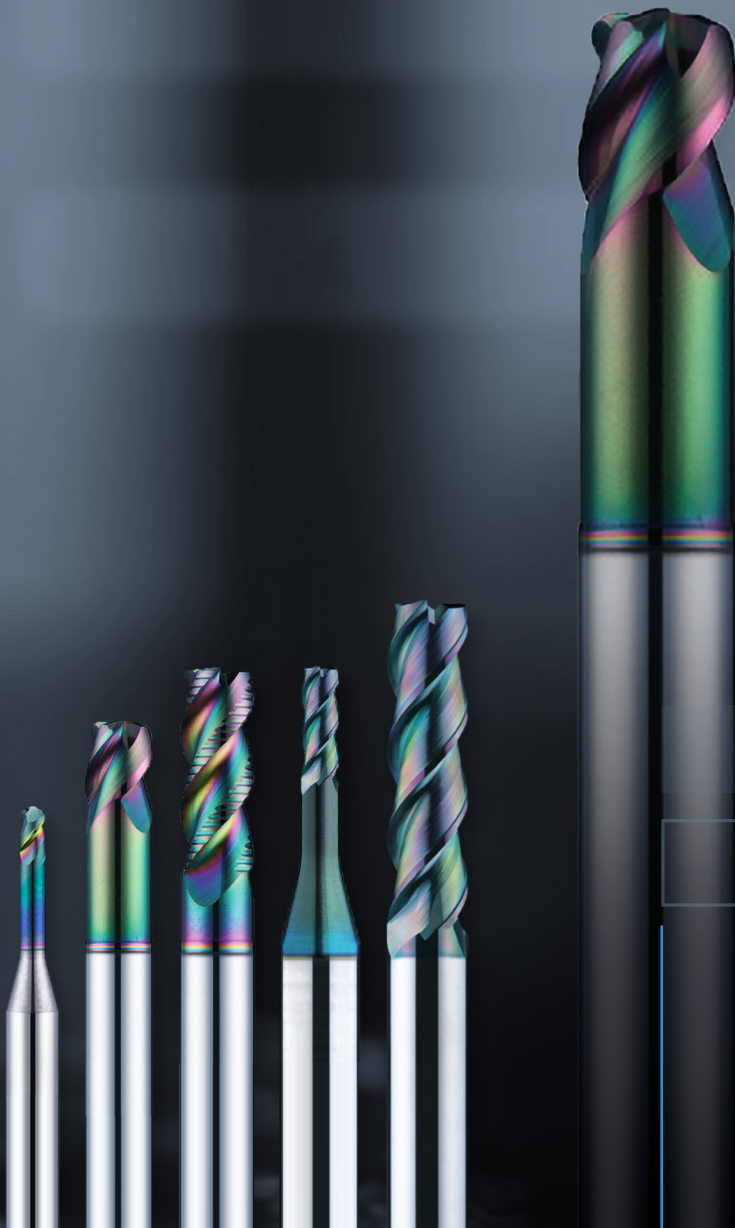

schreurs.
PRÄZISIONSWERKZEUGE

VHM-Schafffräser 3-Schneider für Aluminium, Schaft HA
Solid carbide end mill 3 flutes for aluminium, shank HA

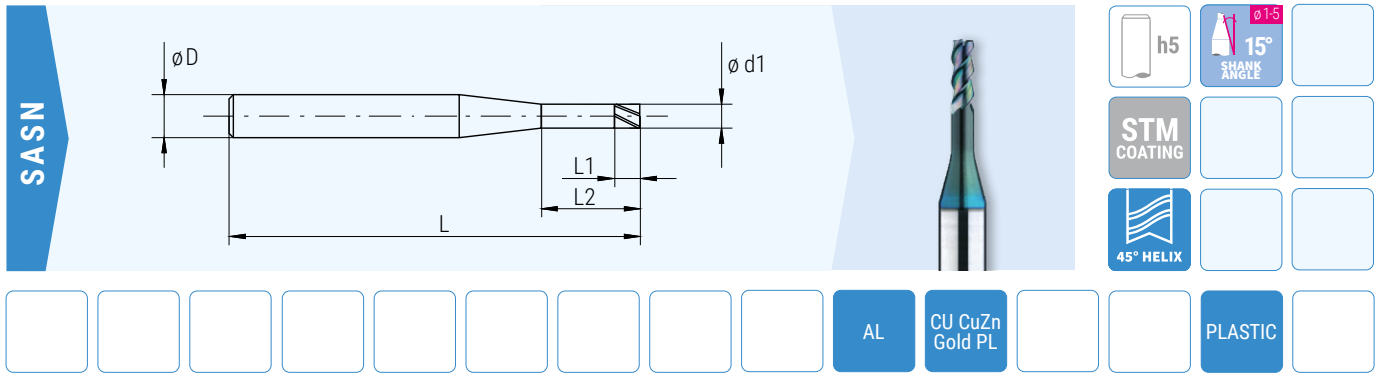

Best.-Nr. / Order no.	d1	L1	L2	L	D	Z
SASN-3008-030-S04-STM	0,8	1,6	3	50	4	3
SASN-3008-080-S04-STM			8			
SASN-3010-040-S06-STM	1,0	2,0	4	60	6	3
SASN-3010-060-S06-STM			6			
SASN-3010-100-S06-STM			10			
SASN-3015-060-S06-STM	1,5	3,0	6	60	6	3
SASN-3015-080-S06-STM			8			
SASN-3015-160-S06-STM			16			
SASN-3020-040-S06-STM	2,0	4,0	4	60	6	3
SASN-3020-100-S06-STM			10			
SASN-3020-200-S06-STM			20			
SASN-3025-100-S06-STM	2,5	5,0	10	60	6	3
SASN-3025-150-S06-STM			15			
SASN-3025-250-S06-STM			25			
SASN-3025-300-S06-STM			30			
SASN-3030-100-STM	3,0	6,0	10	60	6	3
SASN-3030-150-STM			15			
SASN-3030-300-STM			30			
SASN-3030-400-STM			40			
SASN-3040-100-STM	4,0	8,0	10	70	6	3
SASN-3040-200-STM			20			
SASN-3040-300-STM			30			
SASN-3040-400-STM			40			
SASN-3050-100-STM	5,0	10,0	10	80	6	3
SASN-3050-200-STM			20			
SASN-3050-300-STM			30			
SASN-3050-500-STM			50			
SASN-3060-200-STM	6,0	12,0	20	80	6	3
SASN-3060-400-STM			40			
SASN-3060-600-STM			60			
SASN-3060-800-STM			80			
SASN-3080-400-STM	8,0	16,0	40	100	8	3
SASN-3080-600-STM			60			
SASN-3080-800-STM			80			
SASN-3100-500-STM	10,0	20,0	50	110	10	3
SASN-3100-700-STM			70			
SASN-3100-900-STM			90			
SASN-3120-500-STM	12,0	24,0	50	110	12	3
SASN-3120-700-STM			70			
SASN-3120-900-STM			90			
SASN-3160-800-STM	16,0	32,0	80	130	16	3
SASN-3200-1200-STM	20,0	40,0	120	160	20	3
SASN-3200-1500-STM			150			

VHM-Schafffräser 3-Schneider, für Aluminium, lange Schneide, Schaft HA
Solid carbide end mill 3 flutes for aluminium, long cutting edge, shank HA

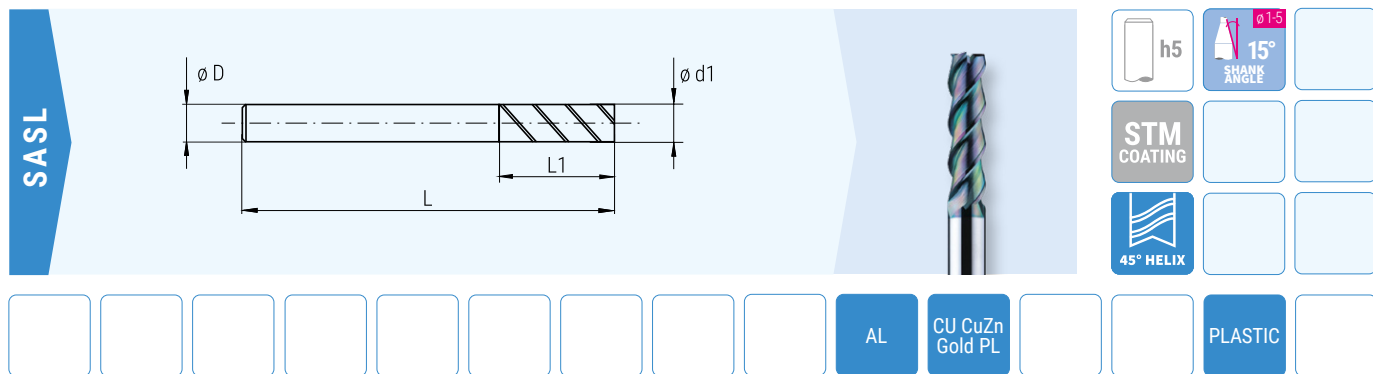

Best.-Nr. / Order no.	d1	L1	L	D	Z
SASL-3010-100-STM	1,0	10	45	6	3
SASL-3015-150-STM	1,5	15	50	6	3
SASL-3020-200-STM	2,0	20	60	6	3
SASL-3025-080-STM	2,5	8	45	6	3
SASL-3025-250-STM		25	65		
SASL-3030-200-STM	3,0	20	55	6	3
SASL-3030-300-STM		30	65		
SASL-3040-200-STM	4,0	20	55	6	3
SASL-3040-300-STM		30	65		
SASL-3050-300-STM	5,0	30	65	6	3
SASL-3050-400-STM		40	75		
SASL-3060-300-STM	6,0	30	70	6	3
SASL-3060-500-STM		50	90		
SASL-3080-400-STM	8,0	40	80	8	3
SASL-3080-700-STM		70	120		
SASL-3100-500-STM	10,0	50	100	10	3
SASL-3100-800-STM		80	130		
SASL-3120-500-STM	12,0	50	100	12	3
SASL-3120-800-STM		80	130		
SASL-3160-800-STM	16,0	80	130	16	3
SASL-3160-1000-STM		100	160		
SASL-3200-1000-STM	20,0	100	160	20	3
SASL-3200-2000-STM		130	200		

VHM-Schrupfräser 3-Schneider für Aluminium, Schaft HA, mit Schrappverzahnung
Solid carbide roughing end mill 3-flute for aluminum, HA shank, with roughing teeth

SARS

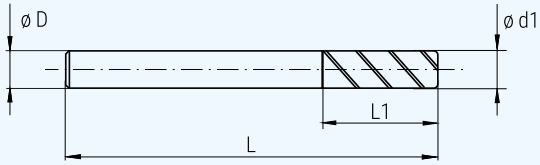



h5

STM
COATING

45°
HELIX

AL

CU CuZn
Gold PL

PLASTIC

Best.-Nr. / Order no.	d1	L1	L	D	Z
SARS-3060-150-STM	6	15	60	6	3
SARS-3080-200-STM	8	20	70	8	3
SARS-3080-300-STM		30	90		
SARS-3100-400-STM	10	40	100	10	3
SARS-3120-300-STM	12	30	80	12	3
SARS-3120-500-STM		50	110		
SARS-3160-420-STM	16	42	100	16	3
SARS-3200-480-STM	20	48	100	20	3

VHM-Kugelfräser 2-Schneider für Aluminium, Schaft HA
Solid carbide ball nose end mill 2-cutter for aluminum, shank HA

SABN

h5

R
 $\pm 0,005$

R
 $\pm 0,01$

STM
COATING

R
 $\pm 0,015$

45° HELIX

15°
SHANK
ANGLE

AL

CU CuZn
Gold PL

PLASTIC

Best.-Nr. / Order no.	d1	ER	L1	L2	L	D	Z
SABN-2005-020-S04-STM	0,5	0,25	0,7	2	45	4	2
SABN-2005-040-S04-STM				4			
SABN-2005-060-S04-STM				6			
SABN-2006-020-S04-STM	0,6	0,30	0,9	2	45	4	2
SABN-2006-040-S04-STM				4			
SABN-2006-060-S04-STM				6			
SABN-2006-080-S04-STM				8			
SABN-2008-030-S04-STM	0,8	0,40	1,2	3	45	4	2
SABN-2008-060-S04-STM				6			
SABN-2008-080-S04-STM				8			
SABN-2008-100-S04-STM				10			
SABN-2008-120-S04-STM				12			
SABN-2010-050-S04-STM	1,0	0,50	1,5	5	50	4	2
SABN-2010-100-S04-STM				10			
SABN-2010-160-S04-STM				16			
SABN-2010-200-S04-STM				20			
SABN-2012-040-S04-STM	1,2	0,60	1,8	4	50	4	2
SABN-2012-060-S04-STM				6			
SABN-2012-080-S04-STM				8			
SABN-2012-100-S04-STM				10			
SABN-2015-050-S04-STM	1,5	0,75	2,0	5	50	4	2
SABN-2015-100-S04-STM				10			
SABN-2015-160-S04-STM				16			
SABN-2015-200-S04-STM				20			
SABN-2020-050-S06-STM	2,0	1,00	3,0	5	50	6	2
SABN-2020-080-S06-STM				8			
SABN-2020-100-S06-STM				10			
SABN-2020-160-S06-STM				16	60		
SABN-2020-200-S06-STM				20			
SABN-2020-250-S06-STM				25			
SABN-2025-060-S06-STM	2,5	1,25	4,0	6	50	6	2
SABN-2025-100-S06-STM				10			
SABN-2025-160-S06-STM				16	60		
SABN-2025-200-S06-STM				20			

VHM-Kugelfräser 2-Schneider für Aluminium, Schaft HA
Solid carbide ball nose end mill 2-cutter for aluminum, shank HA

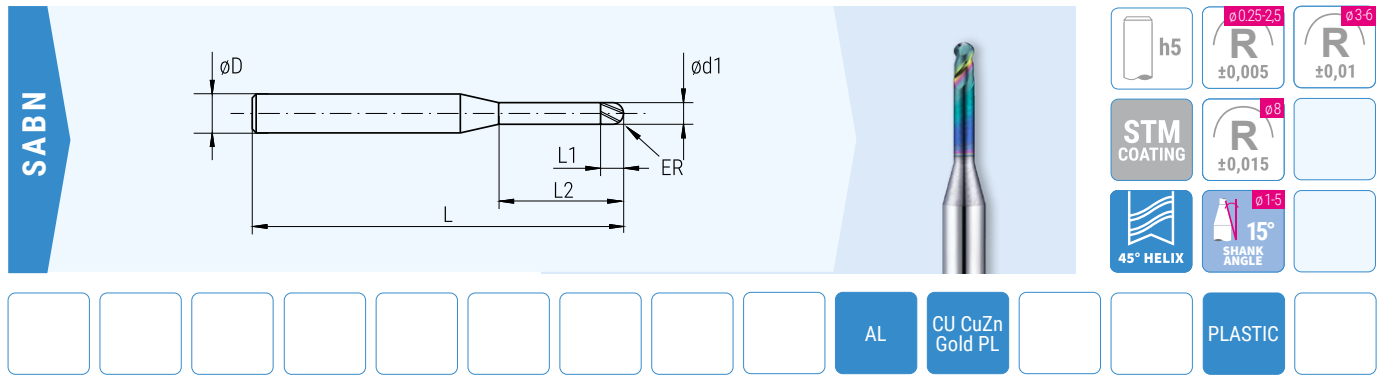

Best.-Nr. / Order no.	d1	ER	L1	L2	L	D	Z
SABN-2030-080-STM	3,0	1,50	4,5	8	60	6	2
SABN-2030-120-STM				12			
SABN-2030-160-STM				16			
SABN-2030-200-STM				20			
SABN-2030-250-STM				25			
SABN-2030-300-STM				30			
SABN-2030-400-STM				40			
SABN-2040-100-STM	4,0	2,00	6,0	10	60	6	2
SABN-2040-160-STM				16			
SABN-2040-200-STM				20			
SABN-2040-300-STM				30			
SABN-2040-400-STM				40			
SABN-2050-160-STM	5,0	2,50	8,0	16	80	6	2
SABN-2050-200-STM				20			
SABN-2050-250-STM				25			
SABN-2060-300-STM	6,0	3,00	9,0	30	90	6	2
SABN-2060-400-STM				40			
SABN-2080-200-STM	8,0	4,00	12,0	20	100	8	2
SABN-2100-250-STM	10,0	5,00	15,0	25	100	10	2
SABN-2120-300-STM	12,0	6,00	18,0	30	110	12	2
SABN-2160-600-STM	16,0	8,00	30,0	60	160	16	2

VHM-Torusfräser 3-Schneider für Aluminium, Schaft HA

Solid carbide end mill with corner radius 3 flutes for aluminium, shank HA

SARN

h5

R $\phi 0.5$
 $\pm 0,005$

R $\phi 1-1.5$
 $\pm 0,01$

STM COATING

R $\phi 2.5$
 $\pm 0,015$

45° HELIX

15° SHANK ANGLE

AL

CU CuZn
Gold PL

PLASTIC

Best.-Nr. / Order no.	d1	ER	L1	L2	L	D	Z
SARN-3030-R005-600-STM	3	0,5	10	15	60	4	3
SARN-3040-R005-600-STM	4	0,5	12	20	60	4	3
SARN-3050-R005-600-STM	5	0,5	15	20	60	6	3
SARN-3050-R010-600-STM		1,0					
SARN-3060-R005-700-STM	6	0,5	7	20	70	6	3
SARN-3060-R010-700-STM		1,0					
SARN-3080-R005-800-STM	8	0,5	9	25	80	8	3
SARN-3080-R010-800-STM		1,0					
SARN-3100-R005-1000-STM	10	0,5	11	30	100	10	3
SARN-3100-R015-1000-STM		1,0					
SARN-3100-R015-1000-STM		1,5					
SARN-3120-R005-1100-STM	12	0,5	13	36	110	12	3
SARN-3120-R010-1100-STM		1,0					
SARN-3120-R015-1100-STM		1,5					
SARN-3120-R020-1100-STM		2,0					
SARN-3160-R005-1300-STM	16	0,5	17	50	130	16	3
SARN-3160-R010-1300-STM		1,0					
SARN-3160-R020-1300-STM		2,0					
SARN-3200-R010-1500-STM	20	1,0	21	60	150	20	3
SARN-3200-R020-1500-STM		2,0					
SARN-3200-R040-1500-STM		4,0					

schreurs-tools GmbH

Präzisionswerkzeuge

Siemensstr. 32

D-71394 Kernen im Remstal

GERMANY

 +49 (0) 7151 / 958 99 - 0

 +49 (0) 7151 / 958 99 - 40

 info@schreurs-tools.de

 www.schreurs-tools.de